



Report of the

Paediatric Death Review Committee

and

Deaths Under Five Committee

**Office of the Chief Coroner
Province of Ontario**

June 2007

Table of Contents

Message from the Chair	1
PDRC—Terms of Reference	2
Classification of Death	3
Child Death Review Process	4,5
Children’s Deaths—Data Overview	6
Accidental Deaths—Drowning	7,8
Youth Suicide in First Nations Communities	9
Deaths Under Five Committee	10
Sudden Infant Death Syndrome (SIDS)	11
Sudden Unexpected Death (SUD)	11
Trends in Infant Deaths	12
Co-Sleeping and Unsafe Sleeping	13
Themes—Medical	14
PDRC—Publications	15–18
Fluid and Electrolyte Administration in Children—Guidelines	19, 20
PDRC Reviews of Cases with Children’s Aid Involvement	21, 22
Themes and Recommendations—CAS	23, 24
Internal Child Reviews: Best Practice Guidelines for Children’s Aid Societies	25
Future Directions	26
Committee Membership and Contact Information	27, 28

Message from the Chair

This is the second report of the Paediatric Death Review Committee. Since the last report in 2004, initiatives involving the Ministry of Children and Youth Services and the Office of the Chief Coroner have provided additional resources, which have enhanced the work of the Committee and allowed for a more detailed report. We have recorded how and why children have died in Ontario, both related to Children's Aid Society (CAS) cases and deaths in the community at large. By understanding this, we are in a much better position to take steps to prevent many of these deaths in the future.

In particular, there has been much debate about the secrecy surrounding CAS deaths, mainly due to privacy legislation. We have tried to enlighten the public in as much detail as possible about these deaths while still respecting privacy issues.

Many recommendations have been made about deaths in the health care system, and deaths related to Children's Aid Societies. Some of the major recommendations involve (1) a safe sleeping environment; (2) accidental drownings; (3) treatment of children in the emergency departments; and, (4) high rate of suicides among First Nations youths.

Comment is made on the lessons learned from reviewing two CAS cases which involved the homicides of children. The particular concerns in each case have been fully addressed with the local Children's Aid Societies. However, the common themes to both cases which are described in the report will be examined in greater detail at two upcoming inquests which are being called by the Office of the Chief Coroner: (1) the Jeffrey Baldwin inquest; and, (2) the homicidal death of a young child at the hands of a young offender.

We all learn more from examining our mistakes than our successes, and that is the theme of this report. Much progress has been made since 2004, but there is still room for improvement. The report is written with the Office of the Chief Coroner's motto in mind "*We Speak For The Dead To Protect The Living*".

I would like to thank all the members of both the Deaths Under Five Committee and the Paediatric Death Review Committee for their ongoing commitment in child deaths reviews. In particular, I am indebted to Ms. Dorothy Zwolakowski and Ms. Karen Bridgman-Acker, without whom the Committees could not function, and this report would certainly not have been written.

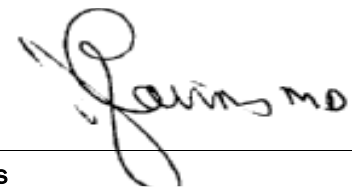

Dr. Jim Cairns
Deputy Chief Coroner for Ontario
Chair, Paediatric Death Review Committee
Chair, Deaths Under Five Committee

Paediatric Death Review Committee: Terms of Reference

To provide expert advice to the Office of the Chief Coroner regarding child death investigations

1. To determine the cause and manner of death.
2. To ensure in medical cases, that an appropriate diagnosis was rendered.
3. To provide expert evidence, where requested, at inquests and criminal proceedings.
4. To do, or promote research where appropriate.
5. When directed, to undertake random reviews, or directed reviews.
6. To provide or stimulate educational activities through identification of problem issues and/or:
 - referral to agencies for action
 - develop of protocols
 - disseminate educational information to parents, hospitals/ professionals, child welfare agencies, government ministries and others

Paediatric Death Review Committee: Medical and CAS Case Reviews 2004 – 2006

The Paediatric Death Review Committee and the Deaths Under Five Committee review a large number of cases annually. The intake, preparation and review of these cases are labour intensive.

In 2004, 60 cases were reviewed by the Paediatric Death Review Committee and of those, 33 cases had Children's Aid Society involvement with the child prior to their death. Of the 33 cases, 1 went to inquest.

In 2005, the PDRC reviewed a total of 49 cases. 28 of those cases had Children's Aid Society involvement with the child prior to their death. The 3 cases

recommended for inquest were of a medical nature and had no Children's Aid Society involvement.

For the year 2006, 86 cases were reviewed (23 Medical and 63 CAS). There was a clear increase in the number of CAS cases the PDRC reviewed in comparison to previous years. This was a direct result of the revised Joint Directive, effective March 31, 2006 allowing for a more timely and streamlined approach to reviewing CAS files.

Manner of Death	2004		2005		2006	
	Medical	CAS	Medical	CAS	Medical	CAS
Natural	21	9	18	10	16	18
Accident	4	11	1	6	1	13
Homicide	0	2	0	0	3	7
Suicide	0	4	0	5	0	9
Undetermined	2	7	2	7	3	9
<i>Ongoing Investigation</i>						7
Total Case Reviews:	27	33	21	28	23	63

Classification of Death

1. Natural:

A death is natural if it is due to a natural disease or known complication thereof; or known complication of treatment for the disease.

2. Accident:

A death is accidental if it is due to an occurrence, incident or event that happens without foresight or expectation.

An accidental death is caused by an external factor, where death or harm was not foreseen or expected.

3. Suicide:

A death is a suicide if it results from an intentional act of a person knowing the probable consequence of what he/she is about to do—that is his/her own death.

The Ontario Court of Appeal in the case *Beckon v. Young* has given specific instructions regarding the standard of proof required for a finding of suicide (Beckon test). While the legal test to be satisfied is a balance of probability, a determination of suicide can only be made where there is clear and convincing evidence. There is to be a presumption against suicide at the outset, and one must be satisfied on a high degree of probability that the death was a suicide.

Suicide is a finding of fact, not of law or morality. A finding of suicide does not imply agreement with, or understanding of the decision of the deceased. It means that the act was initiated by the deceased and it was non-accidental.

4. Homicide:

A death is a homicide if it resulted from the “action of a human being killing another human being” (Oxford dictionary definition).

The action must be non-accidental and originate from a person other than the deceased. A finding of homicide in the coroners’ system is a finding of fact and does not carry with it a determination of guilt. It is however, a serious finding and should be made only on clear and convincing evidence of a non-accidental action of a person that led to the death of another person.

5. Undetermined:

A death is classified as undetermined if: a full investigation has shown no evidence for any specific classification; or there is equal evidence or a significant contest among two or more classifications; or the death is a suicide that does not meet the Beckon test requiring a high degree of probability; or the death is an apparent suicide of a child under the age of 10.

A finding of “undetermined” is a positive and appropriate finding, after a full investigation and careful consideration of all the evidence. It should not be considered a failure to reach a conclusion.

In the Province of
Ontario, death
classification falls into
one of five categories

Child Death Review Process in the Province of Ontario

Overview:

There are approximately 320 coroners in the Province of Ontario. The province is divided into nine regions with a Regional Supervising Coroner overseeing the investigations in each region.

All cases where the deceased child had an open file with a Children's Aid Society (CAS) at the time of death, or within the last 12 months, are reviewed. The Committee reviews medically complex deaths where the cause and/or manner of death may be in question, or where the standard of medical care is in question. The Committee also reviews selected cases where concerns are raised by family members or caregivers. The Deaths Under Five Committee (DU5C) reviews all deaths of children under five years of age in Ontario, assists in the classification of cause and manner of death, and may forward the case for further review to the PDRC as required.

The Regional Supervising Coroner, having decided that the case requires a review, will refer the case to the PDRC for review. Items reviewed by the PDRC will include the Coroners Investigation Statement, autopsy report, toxicology report, ancillary reports, police report, child welfare and medical files. The contents of the file are distributed to the various experts on the Committee and a report is generated by a Committee member who is designated as the primary reviewer. At the monthly meeting, the entire Committee discusses the report and a consensus report, including recommendations, is confirmed by all members. The final PDRC report is forwarded to the Regional Coroner and in cases where the CAS is involved, the supervising agency and the Ministry of Children and Youth Services (MCYS). The Regional Supervising Coroner may decide to send the recommendations to other relevant agencies depending on the circumstances of the case.

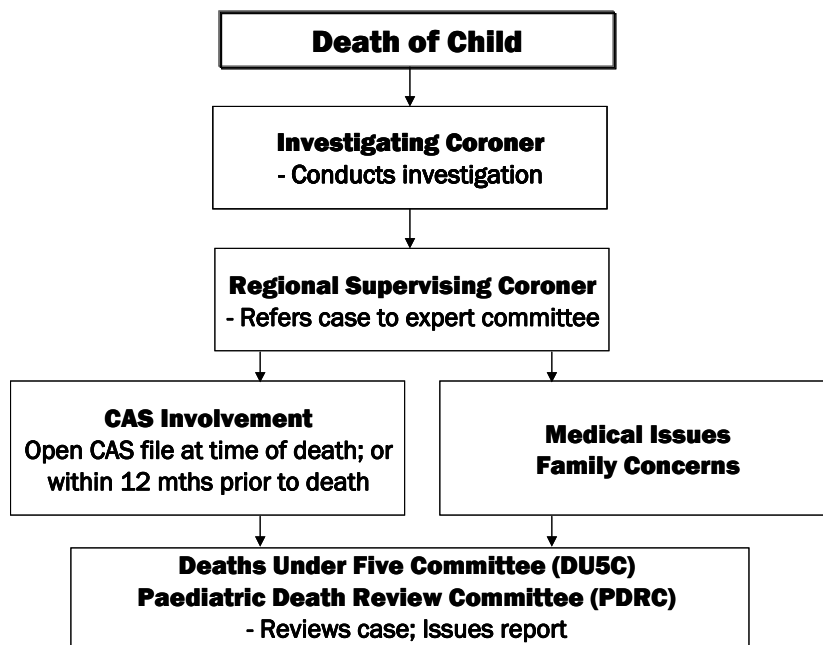

Joint Directive for Reporting and Reviewing Child Deaths in the Province of Ontario

For more than 10 years, the Office of the Chief Coroner, the Ontario Association of Children's Aid Societies and the responsible provincial ministry (Ministry of Community and Social Services and more recently, the Ministry of Children and Youth Services) have been collaborating to provide leadership in responding to the heightened sensitivity and growing concern about child mortality issues. In 1996 a task force was established to look at deaths of children receiving service from a Children's Aid Society; in 1997 and 1998 inquests into some of these deaths made recommendations for the streamlining of procedures for the reporting and review of child deaths. Since 1996, the PDRC has been conducting child fatality reviews on cases with Children's Aid Society involvement. In 1999, a joint directive was developed to guide the process of child death reviews in Ontario; this directive was revised in 2006.

A Joint Child Death Review Committee, co-chaired by the Child Welfare Secretariat and the Office of the Chief Coroner, with representation from Children's Aid Societies, the Ministry of Children and Youth Services' Legal Services Branch, Management Support Branch and Regional Offices was established in July 2005 to consider options for strengthening accountability in the area of child death reporting and review.

As a result of the Joint Committee's work, the Ministry of Children and Youth Services (MCYS), in collaboration with the Office of the Chief Coroner, developed the revised Joint Directive on Child Death Reporting and Review, including timelines for reporting the death of a child. This new directive replaced the previous Joint Directive from 1999.

The revised Joint Directive sets out the procedures to be followed by Children's Aid Societies, the Office of the Chief Coroner and Ministry Regional Offices. The Joint Directive supplements the Ministry's Serious Occurrence Reporting Procedures that include the requirement to report all deaths of clients that occur while participating in a service.

The Ministry of Children and Youth Services, through its regional offices, is responsible for tracking the progress made and responding to the recommendations from the PDRC to individual agencies and to the Ministry itself.

The following chart illustrates the reporting timelines and flow of information between the Children's Aid Societies and the Office of the Chief Coroner.

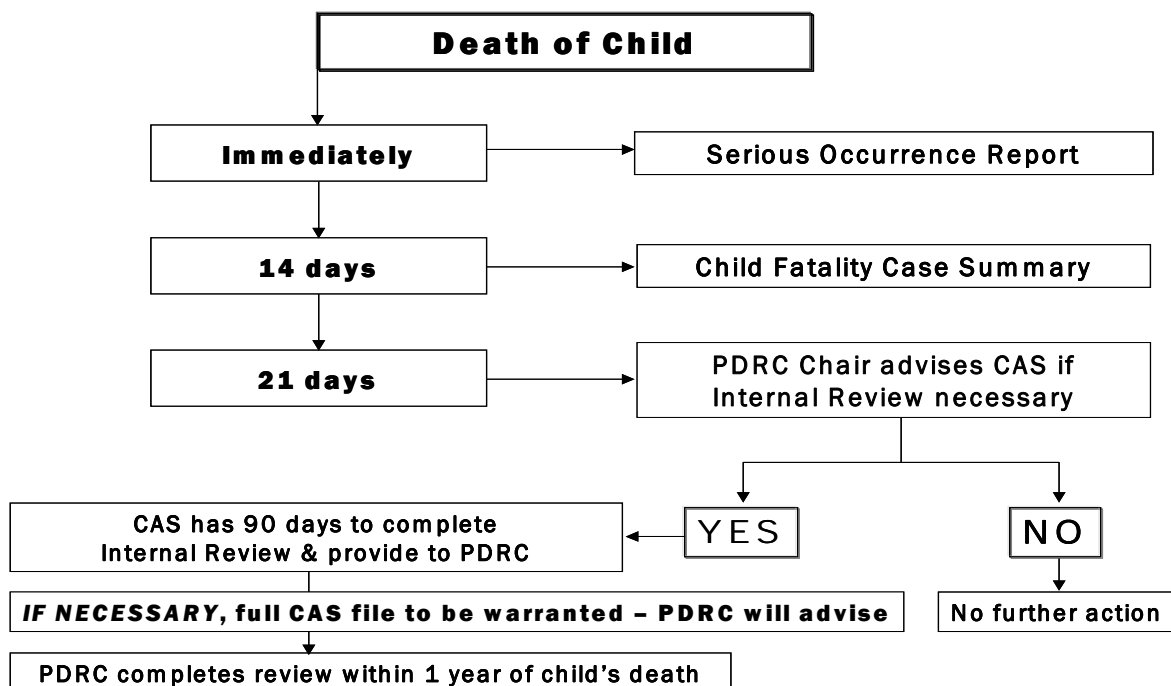

Children’s Deaths in Ontario (0 to 18 years of age): 2001 to 2005

The following table summarizes the children’s deaths investigated by the Office of the Chief Coroner on an annual basis. The statistics for 2004 and 2005 remain preliminary at the time of printing. The deaths reviewed by the PDRC represent a fraction of the total number of children who died in Ontario. Those deaths will be discussed in further detail later in the report.

The following percentages represent the total deaths by manner over this five-year period. Clearly, the largest numbers fall into the *natural* and *accidental* categories.

- Natural:** 45 %
- Accident:** 40 %
- Suicide:** 11 %
- Homicide:** 5 %
- Undetermined:** 10 %

MANNER	2001	2002	2003	2004*	2005*
Natural	250	241	218	229	202
Accident	233	221	198	171	189
Suicide	57	61	56	52	53
Homicide	19	32	30	19	20
Undetermined	51	45	47	42	70
Total Deaths:	610	600	549	513	534

* NB: Preliminary data for years 2004 & 2005

Cases with Children’s Aid Involvement: Deaths Occurring in 2006 (By Manner of Death)

There were a total of 83 deaths in the year 2006, where a child died with an open CAS file at the time of death, or in the 12 months preceding their death.

The average number of paediatric deaths investigated by the Office of the Chief Coroner in the province is approximately 550 per year, therefore, it is noted that the number of deaths where CAS was involved represents a small percentage (~15%) of the total number of paediatric deaths in the province.

NB: The graph represents 60 of the 83 total deaths which occurred in 2006 (23 are still under investigation and manner of death has not been classified).

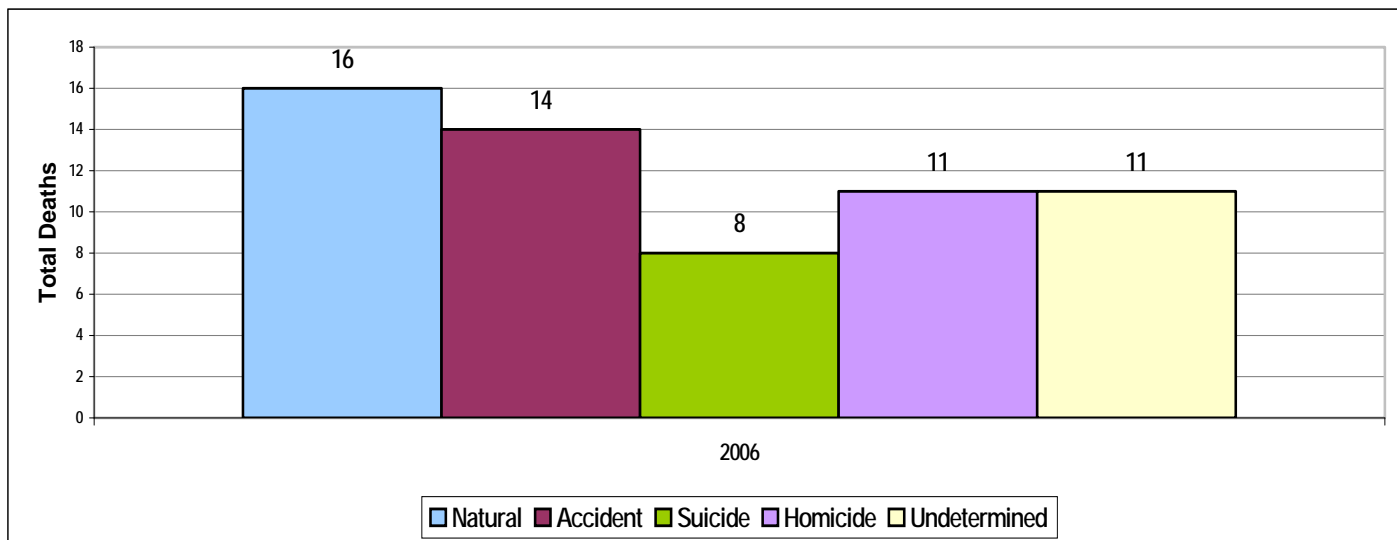

Accidental Deaths—Drowning

Accidental deaths are the second highest percentage of children's deaths investigated by the Office of the Chief Coroner. Of those, drowning is a leading cause.

Research Study—Overview:

50 cases of accidental bathtub drowning over the 19 year period (1986-2004, inclusive) were reviewed. Of those, there were 34 females and 16 males. The ages were predominantly under 2 years (n=24), with a second peak over 10 years (n=13). The older children had either seizure disorders or physical disabilities predisposing to drowning.

Bathseats were involved in 5 cases (7 month old male, left unsupervised for approximately 3 minutes in a bathseat; 12 month old female, left unsupervised for 'one minute' in a bathseat; 7 month old male left unsupervised for 'a few minutes' in a bathseat; 6 month old female left unsupervised for a short period in a bathseat; and a 12 year old male left unsupervised in a specially-designed gurney for 5 minutes). The latter case was a child with severe cerebral palsy. The most common reasons for leaving the children unsupervised were domestic chores (left room to collect towels, clothing), and being called away by a phone call.

Safety Reminder

Parents and caregivers are reminded that they **must be present** and **watching at all times** when an infant or young child is:

- in a bathtub;
- in, or near, a pool;
- or other body of water.

This applies **especially when** an infant is in a bathseat or flotation device. These devices are designed to assist the parent/caregiver, not replace their presence or supervision.

Ref: Health Canada: Consumer Product Safety:
Facts for Infant Bath Seats and Bath Rings
http://www.hc-sc.gc.ca/cps-spc/pubs/cons/bath_seat-sieges_de_bain_e.html

**Drownings: 2001 to 2005
(by Death Factor)**

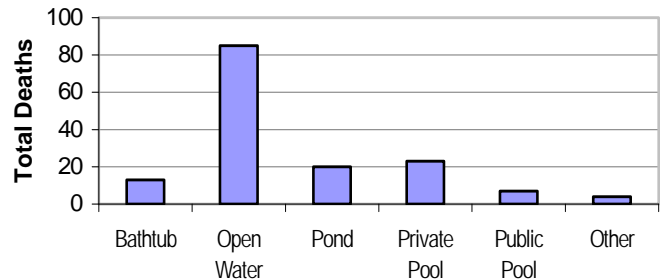

**Drownings: 2001 to 2005
(by Age)**

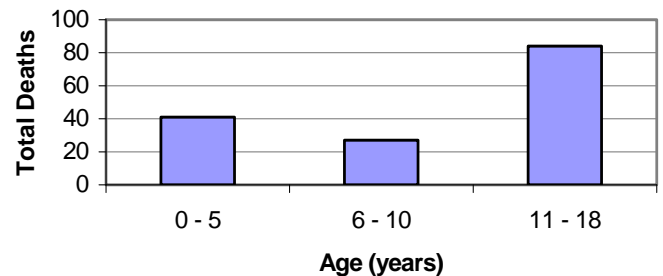

**Drownings: 2001 to 2005
(by Manner of Death)**

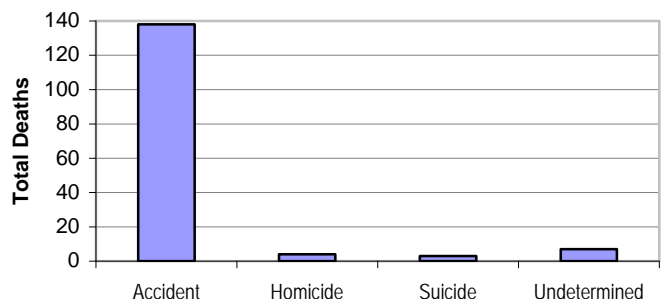

Accidental Bathtub Drownings in Infants and Children in the Province of Ontario—A Study of 50 Cases

The following abstract was delivered as a platform presentation at the National Association of Medical Examiners (NAME) meeting in San Antonio, Texas in October 2006.

Background:

Bathtub drownings are a significant cause of mortality in the paediatric population and several studies have suggested that preventative campaigns have been ineffective in the prevention of such deaths. In order to obtain a better understanding of the factors associated with accidental bathtub drownings, a retrospective review of all cases occurring in the Province of Ontario during a 19 year period (1986-2004) was performed.

Design:

The database of the Office of the Chief Coroner of Ontario was searched for cases of bathtub drownings in children 18 years and under. Those cases where the manner of death was deemed suicidal, homicidal or undetermined were excluded. Information obtained from the files included: the age and gender of the decedent, level of supervision, history of co-bathing with siblings, use of bathseats, presence of seizure disorders or other medical conditions, and results of toxicological analyses. Age clusters were defined as 0-1 yr, 2-5 yr, 6-10 yr and >10 yr.

Results:

Fifty cases of accidental bathtub drownings were identified in 34 females and 16 males ($p=0.0044$). There was no significant trend over the 19 year period. The mean age was 5yr 6m, with no significant difference between males and females. Most decedents were aged 0-1 yr ($n=24$, 48%), with the next largest group being those over the age of 10yr ($n=14$, 28%).

All those aged 0-1yr were without adult supervision at the time of drowning. The most common reasons for lack of supervision were: domestic chores, being called away to the telephone and falling asleep while the infant/child was in the bath. The use of infant-type bathseats was seen in five cases (10%), and co-bathing with other children was seen in ten cases (20%). Seizure disorders were present in only four children aged five years and under, but in 13 children aged over 5 years (13% vs 87%; $p<0.0001$).

Conclusion:

The current study found that the most common victims of bathtub drowning are children aged under two years and older children with seizure disorders. The most frequent risk factors were a lack of supervision, co-bathing and bathseat use. The findings suggest that educational campaigns emphasizing constant supervision may reduce the number of bathtub drownings in both pre-ambulatory children and older children with seizure disorders.

GR Somers, D Zwolakowski, B McLellan, J Cairns, DA Chiasson

Pediatric Forensic Pathology Unit, Hospital for Sick Children; Department of Pathobiology and Laboratory Medicine, University of Toronto; Office of the Chief Coroner, Toronto.

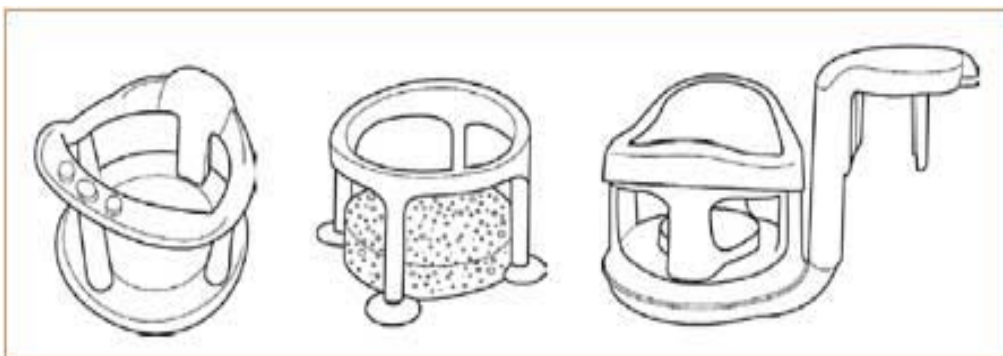

Babies in infant bath seats or bath rings have drowned when:

- the suction cups became loose and the seat tipped over;
- the baby slipped through a leg opening of the seat; or
- the baby tried to climb out of the seat.

Ref: Health Canada: Consumer Product Safety:

Facts for Infant Bath Seats and Bath Rings

http://www.hc-sc.gc.ca/cps-spc/pubs/cons/bath_seat-sieges_de_bain_e.html

Youth Suicide in First Nations Communities

The PDRC is gravely concerned with the pattern and number of suicides amongst First Nations youth (see graph below). The case histories of these young people reveal problems with substance abuse, poverty, inadequate parenting, violence, mental health problems, sexual abuse, rejection and multiple placements. For those who leave suicide notes, they describe feelings of hopelessness, despair, and isolation. The PDRC recognizes the continuous efforts of the Children's Aid Societies and others in Northern Ontario to address these issues.

8 adolescents involved with a Children's Aid Society (CAS) committed suicide in 2006; 5 were First Nations youth. The PDRC reviewed 9 cases of youth suicide in 2006 (5 from 2005 and 4 from 2006), 6 were identified as being from First Nations communities.

Recommendations:

Given the entrenchment of the issues that contributed to the early death by suicide of First Nation youth, the following were offered as possible areas for further investigation, activity and learning:

1. The CAS is to regularly perform internal file reviews and to identify recommendations to support staff in performing their work with vulnerable youth.
2. The CAS is to continue to follow-up and intervene with surviving children and families to ensure safety plans and support are in place.
3. The CAS is to continue the use of the High Risk Child in Care Planning conferences as a promising practice.
4. It is obvious that the parents' ability to set limits, supervise and support their youth is key to any changes. The deep-seated and long standing issues of the parents, in many of these cases, make it unlikely that there will be any meaningful change unless the approach and commitment to suicide prevention is community wide.
5. The role and effectiveness of the school and mental health services in First Nations Communities are key components in all of these deaths. Some form of community review of these cases, which should include the Band Council and the elders, may lead to the development of greater capacity to assess and act on youth at risk. Community consultation, communication and collaboration are key if any change is to occur.
6. Several of the youths gave warnings to peers, family members or service providers prior to committing suicide. It is recommended that CAS and communities develop strategies for educating young people and parents about how to respond when a child is talking of self-harm.
7. Recently the national media has profiled concerns about the conditions in Canadian First Nations Communities; several community groups, notably Save the Children and the North-South Partnership for Children, have brought forth offers of support, aid, and funds in hopes of making a significant difference in the lives of these families. It is strongly recommended that the Ministry of Children and Youth Services work closely with, provide resources to, and support the local child welfare agencies in achieving these goals.
8. The PDRC is aware of a Prevention and Support Program proposal prepared by northern Societies and recommends the Ministry Of Children and Youth Services work with the agencies in obtaining financial as well as support in principle for the development and implementation of these programs.

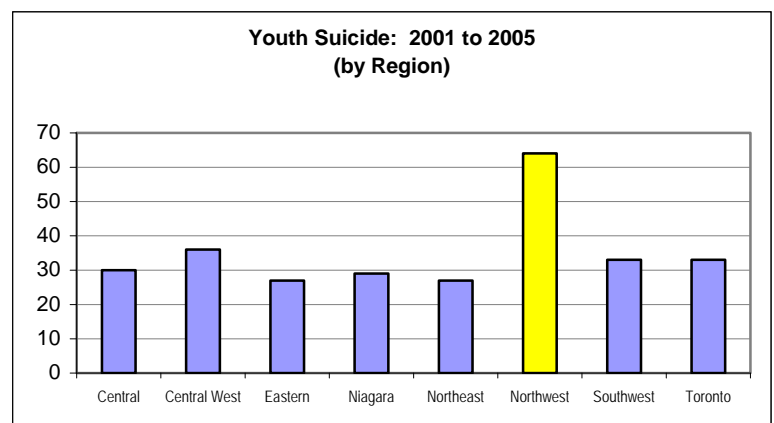

Northwest Region contains the highest number of First Nations youth in the Province of Ontario.

Deaths Under Five Committee

In 1995, the Office of the Chief Coroner introduced a protocol to be used in investigating the death of any child under 2 years of age. Over the years, the protocol has been significantly refined, and in December 2006, it was felt appropriate to issue an up-to-date version of the protocol, to be used by the death investigation team (police, coroners, pathologists) to investigate sudden and unexpected deaths of all children **under 5 years** of age. As a result, the *Deaths Under Two Committee* has been renamed the *Deaths Under Five Committee* to encompass the new age range.

Coroners and other members of the death investigation team are once again reminded of the importance of not reaching a conclusion that death was due to Sudden Infant Death Syndrome (SIDS) until the investigation is complete. This includes a full police investigation, a forensic autopsy at one of the designated paediatric units (including x-rays, histology and toxicology), and review by the Deaths Under Five Committee at the Office of the Chief Coroner. It has recently been brought to our attention that on occasion families, CAS and police are being advised that deaths are due to SIDS before the investigation is complete. In many cases, this means that police and the CAS shut down their investigations prematurely.

The *Deaths Under Five Committee* reviews and classifies the cause and manner of death in all deaths of children under five years of age.

National Association of Medical Examiners (NAME) Guidelines for Classifying Deaths

The Office of the Chief Coroner uses the National Association of Medical Examiners (NAME) guidelines when classifying infant deaths. This allows for consistent classification in the Coroners system. The following NAME Guidelines have been used by the Paediatric Death Review Committee and Deaths Under Two Committee (now the Deaths Under Five Committee) since 2002:

Definitions:

COD: Cause of Death

BWM: By What Means (Manner of Death)

Group 1	COD: A specific disease, injury, or other condition is identified as cause of death (i.e. pneumonia, CHD, overlaying, head trauma, etc) BWM: Classified based on the circumstances
Group 2	COD: "Classic" SIDS – no cause of death identified after complete autopsy, toxicology, other lab tests, scene investigation, review of medical history. BWM: Natural
Group 3	COD: Consistent with SIDS – but evidence of a disease condition (such as focal bronchiolitis) is found but the role of the condition in causing or contributing to death is not known BWM: Natural
Group 4	COD: Sudden unexpected death in infancy – evidence of external condition or risk factor exists (bedsharing with adults, sleeping face down on a soft pillow or adult mattress). Again the role of the external condition/risk in causing or contributing to the death is not truly known or difficult to evaluate, prove, or disprove. BWM: Undetermined (also list the contributing external factors)
Group 5	COD: Unexpected and undetermined cause BWM: Undetermined

Age 0 to 5 yrs	2001	2002	2003	2004*	2005*
Manner of Death					
Natural	173	176	156	180	135
Accident	61	48	35	34	34
Homicide	7	14	11	5	7
Undetermined	41	38	38	36	57
Total	282	276	240	255	233

* NB: Preliminary data for years 2004 & 2005

SIDS: Sudden Infant Death Syndrome

SIDS is a diagnosis of exclusion, providing all other aspects of the death investigation are negative.

Sudden Infant Death Syndrome (SIDS) is defined as the sudden death of an infant under one year of age, which remains unexplained after a thorough case investigation, which must include a complete autopsy, examination of the death scene, a police investigation and a review of the clinical history.

It is clear from this definition that the diagnosis of SIDS cannot be made by autopsy alone, but can only be made by the Coroner when the results of the full investigation (police, autopsy, x-rays, toxicology, clinical history) are known.

SIDS is a diagnosis of exclusion.

SUD: Sudden Unexpected Death

Contributing Factors Include:

- Co-sleeping
- Sleeping face down
- Unconventional sleeping surface (i.e. adult bed, sofa, car seat)

A sudden unexpected death in infancy may be due to:

1. SIDS
2. Accidental injury
3. Non-accidental injury due to: (a) neglect; (b) abuse
4. A previously undiagnosed natural disease process

If **any** part of the death investigation in a child under one year of age is positive then the death will not be classified as a SIDS. The following are some examples where this would apply:

- a) Negative autopsy but evidence of an old healed fracture, which has not been adequately explained by the investigation.
- b) Negative autopsy but a previous history of child abuse.
- c) Negative autopsy but some positive toxicology, which although not considered to be a cause of death cannot be explained

Where there is any significant concern regarding any part of the death investigation the cause of death should be classified as a "Sudden Unexpected Death", and the manner of death will be recorded as "undetermined".

The data below represents a retrospective file review. It is important to highlight the following findings:

- Infants who died suddenly and unexpectedly had other factors that may have contributed to their death such as co-sleeping with an adult; sleeping on their stomach face down; or in an unsafe sleeping environment such as an adult bed, car seat, or couch.
- Male infants represented a larger percentage of deaths in the SIDS/SUD category: 69% in 2004; 63% in 2005
- The average age of infants at time of death was 3 months.
- Age range of mother: 17–29 years; age range of father: 17–30 years.
- Smoking during pregnancy; and/or smoke exposure in the household: 73% in 2004; 77% in 2005
- CAS Involvement with family prior to death or at time of death: 30% in 2004; 26% in 2005.

Cause of Death	2004	2005
SIDS	10	6
SUD with co-sleeping and/or unsafe sleeping environment*	16	21

* **Co-sleeping:** infant sleeping with adult on an adult-size bed, couch, or floor

Unsafe sleeping environment: make-shift bed (foam mattresses pushed together on floor); waterbed; car seat in home; adult-size bed surrounded by pillows and adult-size bedding; soft couch

Trends in Infant Deaths in Ontario

- Decrease in the number of SIDS
- Increase in the number of SUD
- Unsafe sleeping, co-sleeping/bed-sharing were contributing factors to the SUD total
- Ontario in 2005 – 6 SIDS; 21 SUD (with co-sleeping or unsafe sleeping as a contributing factor)
 - 11/21 SUD deaths involved bed sharing with an adult or sibling
 - 10/21 SUD deaths involved an unsafe sleeping environment (adult bed, couch, crib with extra bedding, pillows, toys)

According to Statistics Canada:

- During the past 25 years, the infant mortality rate in Canada has declined by 52%.
- The infant mortality rates in Canada for 2004 have remained stable compared to 2003 at 5.3 deaths per 1,000 live births.
- Between 2003 and 2004, the infant mortality rate for babies under one year of age increased in 5 provinces and territories, including Ontario, where the rate was 5.5 per 1,000 live births.

In 1991, there were approximately 140 deaths classified as SIDS in the Province of Ontario. Clearly, since that time, the numbers have decreased to approximately 10 per year. The reasons being:

- 1) **Education:** Back to Sleep Program -referring to placing a baby on their back (supine position) when putting them down to sleep.
- 2) **Stricter Definition of SIDS:** The Office of the Chief Coroner uses the National Association of Medical Examiners (NAME) guidelines when classifying infant deaths. This allows for a consistent classification in the Coroners system.
- 3) **Deaths Under Five Investigation Questionnaire:** Designed by the Coroner's Office, the questionnaire assists coroners and police officers to ensure that all aspects of a comprehensive scene investigation are covered.

Reducing the chances a baby will die from SIDS or SUD

DO

- place them down for sleep only on their back until they are one year of age
- put them on a firm mattress in a crib
- keep the baby's room temperature cool (about 65 degrees) when he or she is sleeping
- encourage the baby's mother not to smoke while she is pregnant or afterward around her baby and not to take the baby into smoke-filled environments
- encourage the baby's mother to breastfeed the child. If mother is a heavy smoker and breast-feeds, please ask her to talk with her doctor.
- encourage the baby's parents to seek medical care for the baby when he or she becomes ill
- tell other caregivers of the baby (parents, aunts, uncles, babysitters, etc.) to follow these simple rules, too!

DON'T

- use pillows, crib bumper pads, blankets, afghans, or quilts (especially adult bedcovers), over or under them
- smoke around babies or let anyone else smoke around them
- overdress or overheat the baby, especially if he or she is ill
- let babies share a sleep surface with another child or with an adult
- put babies in an adult bed or on a sofa to sleep!

Co-Sleeping and Unsafe Sleeping

Infants who sleep with adults are at an increased risk of overlay death especially when the adults are obese and/or impaired by drugs or alcohol.

Overlaying deaths are those caused by persons that accidentally lay on top of a child. Infants are at increased risk for overlaying death as they are often not strong enough to move their heads or bodies.

The PDRC urges Children's Aid Societies, public health departments, maternity wards and other agencies to develop and/or continue their education efforts on unsafe sleeping environments for new families.

Internationally, agencies have issued cautions regarding the dangers and risks associated with unsafe sleeping arrangements.

Safe Sleeping Position Statements and/or Warnings Issued:

1999 – U.S. Consumer Product Safety Commission
 1999 – American Medical Association
 1992/2000/2005 – American Academy of Pediatrics
 2004 - U.K. Department of Health
 2004 – Canadian Paediatric Society

Surfaces **Not** Designed or Approved for Infants' Sleep

Adult beds
 Infant swings
 Playpens
 Bassinets
 Cradles
 Waterbeds
 Couches
 The floor
 Mattresses on the floor
 Car seats
 Soft bumper pads, pillows, quilts, stuffed toys
 (see Figure 2 below)



Figure 1: Safe sleeping (baby blanket tucked in; no other items in crib)

Figure 2: Unsafe sleeping environment

Case Examples

The following 3 cases illustrate the risks associated with co-sleeping and unsafe sleeping environments:

A 2-month-old infant in bed with her mother and boyfriend all of whom were sleeping on a pull-out sofa bed with a soft mattress. 3 hrs later, the boyfriend went outside to smoke and mother awoke to find her baby not breathing.

A 4-month-old infant in bed with mother, father and 2-year-old sibling, all sleeping on a queen-size bed with adult bedding (pillows, comforter). The night before the parents were consuming alcohol and marijuana. The following morning (6 hrs later), parents discovered the infant to be deceased.

A 5-week-old infant put to sleep on its stomach in crib after bottle-feeding at 11 pm. At 8:30 am, the mother entered the room to find the infant unresponsive and face down in bedding. The crib contained several adult size pillows, adult comforter, stuffed toys (see photos on right).



Side and overhead view of crib containing multiple objects creating a hazardous sleep environment

Medical Case Reviews: THEMES

Since its inception in 1991, the Paediatric Death Review Committee has compiled a number of common themes that have recurred in the review of children's deaths. Our reviews echo the findings of an increasing volume of literature on errors in medicine, which suggests that tragedies rarely result from a single fatal error or flaw and are more likely to arise from a series of latent flaws in both systems and in performance. The occurrence of multiple imperfections is frequently synergistic. Latent flaws, which may appear quite basic, but are seen repeatedly by the Committee:

- Failure to **listen** to repeated parental concerns, particularly in the child who returns without having responded to initial medical management
- Failure to record or review **vital signs**, particularly blood pressure – **VITAL SIGNS ARE VITAL!!!!**
- Failure to make a semi-quantitative assessment of **fluid intake and output**, particularly in the child with vomiting and diarrhea (e.g. number of loose stools, wet diapers etc)
- Where lab tests are ordered, particularly in an emergency department, it is essential that the results of these tests be known **before a decision is made regarding further treatment**
- **Illegible or sloppy handwriting**, which is misinterpreted by others
- Failure to record **thought processes**, or the reasons behind certain actions – the more badly things are going, the more important charting becomes (and the less likely complete charting is to be found)
- Failure to record **weight** or to use **growth charts**
- Failure to include not only the **date**, but the **time** of a chart entry
- Failure to **follow-up on missed appointments**, especially for the “non-compliant parent and non-responsive patient”
- Failure of an institution to **meet with the parents** after a death to discuss and review the care provided. Not infrequently, such a failure has led to a physician not only being regarded as heartless, but as having something to hide, which may result in parents pushing for inquests where a less adversarial process may have been more helpful
- Refusal to **accept alternative explanations** after the event, even after review by third parties

Coroner's Corner

Rapid onset of coma and death in the initial presentation of type 2 diabetes in an 11-year-old-child

The following two articles were authored by the Paediatric Death Review Committee and published in the journal of *Paediatrics and Child Health* in an effort to alert and educate the medical community.

An 11-year-old First Nations child weighing 100 kg presented to a community health centre in a remote community complaining of a sore throat for four days. A throat swab to screen for group A streptococcus was negative. She had experienced some diarrhea and vomiting for two days before being seen, but it had resolved. Forty-eight hours later, the mother called Telehealth Ontario to report that her daughter was breathing fast and shallow for 1 h. It was recommended that she go immediately to the emergency department. In that setting, she was noted to have a capillary blood glucose level of 17 mmol/L.

Four years before this admission, it was noted that she was overweight and had a positive family history, in first- and second-degree relatives, of type 2 diabetes. Random test results of blood sugar, fasting blood sugar, HbA1c, cortisol and thyroid-stimulating hormone levels were all normal. From that date until four years later, there were no documented laboratory investigations in the chart. It was reported, however, that she was part of a diabetic screening program in that community. The program consisted of capillary blood glucose testing on a yearly basis. It was reported that her capillary blood glucose was normal six weeks before death, but written documentation of that report could not be found. Her parents reported that her blood sugar tested at home 24 h before being seen in the first hospital was 5.6 mmol/L.

On admission on this occasion, her temperature was 36.4°C, heart rate 122 beats/min, respiratory rate 30 breaths/min and blood pressure 122/84 mmHg. Her Glasgow Coma Scale (GCS) score was 12 en route by ambulance. She was agitated, awake and not responding to questions. Twenty-five minutes later, her blood pressure was 174/85 mmHg, and she remained hypertensive for the next 8 h. Her urine was strongly positive for ketones and glucose. An intravenous (IV) was established with difficulty 1 h after admission. She was given 10 units of regular insulin by IV push, and 2 L of normal saline were given over 2 h. She passed 1100 mL of urine. Normal saline with 20 meq/L of potassium chloride was then started at 100 mL/h. Eight hours after admission, arrangements were made to transfer her to a tertiary care centre. At this time, her GCS had dropped from 12 to 6.

During transfer, her GCS dropped further to 3, and she became hypotensive. As a result, the transfer was diverted to a closer centre.

In that setting, 8 h after her initial presentation, her blood sugar was 33 mmol/L (no glucose had been given intravenously). Her sodium level was 137 mmol/L, potassium 6.4 mmol/L, chloride 107 mmol/L, bicarbonate 5 mmol/L, pH 6.89, pCO₂ 23 mmHg, hemoglobin 160 g/L, urea 11.6 mmol/L, creatinine 187.7 µmol/L, lipase 10902 U/L and lactic acid dehydrogenase 966 U/L.

A central venous catheter was established, and she was intubated and ventilated. The possibility of cerebral edema was entertained, and mannitol 25 g over 20 min was given. An insulin infusion was established at 0.1 units/kg/h. A computed tomography scan of the head showed no evidence of cerebral edema. Eleven hours after her initial presentation, she became hypotensive and failed to respond to saline bolus. A dopamine infusion was established. Her GCS remained at 3 for the 5 h she spent in the second hospital. During this time, she received 2500 mL of normal saline, 500 mL of 3% saline and 500 mL of mannitol. She passed 1000 mL of urine.

She was then transferred to the original tertiary care destination. In that setting, she presented with multiple organ failure. Her first serum osmolality measured 22 h after the initial presentation was 359 mOsm/kg. She failed to respond to treatment. Her pH remained below 7.1, she became anuric, and terminally had a potassium level of 6.3 mmol/L. She died 2.5 days after admission. Other investigations done during her stay found an HbA1c of 0.115, cholesterol 2.92 mmol/L, triglycerides 4.18 mmol/L, lipase 916 U/L, pancreatic amylase 214 U/L, creatine kinase 22165 U/L and urine myoglobin higher than 10,000 µg/L.

Examination of the pancreas at autopsy “showed no clear morphological evidence of diabetes mellitus. Type 1 diabetes can be excluded on the basis of no inflammatory infiltrate and no apparent decrease in the population of beta cells. The absence of hyperplasia of beta cells weighs against a prediabetic state for type 2 diabetes, and the absence of islet amyloidosis or reduced beta cell population is against established type 2 diabetes.” There was no evidence of cerebral edema.

The Paediatric Death Review Committee is presenting this case to alert caregivers to the risk of potential rapid deterioration of type 2 diabetes, with subsequent fatal outcome in children.

Coroner's Corner

Children with type 2 diabetes can present with diabetic ketoacidosis (DKA), hyperglycemia, hyperosmolar hyperglycemic syndrome (HHS) or a mixed picture of both entities (1-4). We believed that this child presented with a mixed picture of DKA and HHS.

This child was at risk for type 2 diabetes, given her ethnicity (First Nations), her obesity, and a family history of first- and second-degree relatives with type 2 diabetes. Her parents reported in retrospect that she had acanthosis nigricans on her neck, although this was not documented in the chart.

The typical triad of HHS (blood glucose over 33 mmol/L and serum osmolality over 320 mmol/kg in the absence of severe acidosis and ketosis) is not always present and may overlap with DKA, making the diagnosis difficult. The presence of urine ketones and acidosis should not preclude the diagnosis of HHS (1).

The autopsy findings in the pancreas were not associated with type 1 changes seen in children or established type 2 diabetes seen in adults. There are very few reported cases of the autopsy findings in the pancreas of children with type 2 diabetes. The significance of these observations will not be known until other cases are reported.

The Canadian Paediatric Society suggests screening for type 2 diabetes by obtaining a blood sugar level in all children encountered during a health care visit who are of aboriginal descent, aged 10 years or older, and have a body mass index in the 85th percentile or higher (5). These children often live in remote northern communities with nurse practitioner-staffed health centres. Physicians giving advice to these centres and all caregivers involved in the care of this at-risk population should be aware of the potential for type 2 diabetes to deteriorate rapidly, as presented in this case report.

Acknowledgements:

The patient's parents are thanked for their assistance in preparing this article and for permission to print it.

References:

1. Carchman RM, Dechert-Zeger M, Calikoglu AS, Harris BD. A new challenge in pediatric obesity: Pediatric hyperglycemic hyperosmolar syndrome. *Pediatr Crit Care Med* 2005;6:20-4.
2. Morales AE, Rosenbloom AL. Death caused by hyperglycemic hyperosmolar state at the onset of type 2 diabetes. *J Pediatr* 2004;144:270-3.
3. Sellers EA, Dean HJ. Diabetic ketoacidosis: A complication of type 2 diabetes in Canadian aboriginal youth. *Diabetes Care* 2000;23:1202-4.
4. Pinhas-Hamiel O, Dolan LM, Zeitler PS. Diabetic ketoacidosis among obese African-American adolescents with NIDDM. *Diabetes Care* 1997;20:484-6
5. Canadian Paediatric Society, First Nations and Inuit Health Committee [Principal author: Kent Saylor]. Risk reduction for type 2 diabetes in Aboriginal children in Canada. *Paediatr Child Health* 2005;10:49-52. <www.cps.ca/english/statements/II/FNIH05-01.htm> (Version current at December 12, 2006).

Coroner's Corner**Circumcision: A minor procedure?**

A male infant at 37 weeks' gestation was born as a spontaneous vertex weighing 3.9 kg, with Apgar scores of seven at 1 min and nine at 5 min. Prenatally mild bilateral dilation of renal pelvises and ureters was noted on ultrasound. A urology consultation at 36 weeks' gestation suggested a possible normal variant and recommended a kidney ultrasound at three to five days postdelivery, with a voiding cystourethrogram to be performed if the dilation persisted.

The baby was bottlefed and was reported to be doing well when he was circumcised using a PlastiBell ring (Hollister, USA) at 1000 hrs on the seventh day of life. Local anaesthetic was not used. Some slight oozing was noted during the procedure but it was not a problem at discharge.

Five hours later, the parents returned to their family doctor with the infant, reporting that he was very irritable and had blue discoloration below the umbilicus when he cried. The doctor confirmed this observation and noted that the penis was slightly swollen. The abdomen was soft and non-tender with bowel sounds noted. He was seen in-hospital shortly after by a paediatrician, who again noted the blue discoloration below the umbilicus, especially with crying, and some slight swelling of the penis. He had several loose stools, and it could not be determined with certainty whether he had voided. His temperature was 37.8°C and his respiratory rate was 38 breaths/min. There was good capillary refill in the legs; they were warm, and peripheral pulses were palpated. His blood pressure was 80/65 mmHg in the arm and 120/75 mmHg in the leg, and his heart rate was 196 beats/min. The baby was subsequently discharged home.

The infant was brought to a different hospital 14 hrs after the circumcision. He was now noted to be extremely irritable, with marked swelling of the penis and with bruising, swelling and cyanosis of the scrotum and perineum. He had grunting respirations and was cyanotic below the umbilicus. His temperature was 38.8°C, heart rate 190 beats/min, respiratory rate 24 breaths/min, saturation 98% in room air and blood pressure 104/34 mmHg. A blood culture was obtained, which subsequently grew *Escherichia coli* sensitive to ampicillin and gentamicin, which were started at this time. His white blood cell count was $2.2 \times 10^9/L$, with 35% bands. The immature to total neutrophil ratio was 1.3. His platelet count was $221 \times 10^9/L$ and hemoglobin was 163 g/L. He was transferred to a tertiary care centre, where the bladder was identified as being distended to the level of the umbilicus. The PlastiBell ring was removed 16 h after the circumcision and a catheter was passed. The bladder was

drained and the bluish coloration below the umbilicus subsided. Urine volume was not recorded. Over the next few hours, the infant went into septic shock with purpura fulminans, and went on to develop multiorgan failure and disseminated intravascular coagulopathy, with a partial thromboplastin time of 1.01 min, an international normalized ratio of 2.63 and a platelet count of $80 \times 10^9/L$. He died seven days after his circumcision from hypoxic-ischemic encephalopathy. The infant was not considered to have necrotizing fasciitis.

At autopsy, mild dilation of both kidney pelvises and ureters was noted. The bladder and urethra were normal.

Complications of meatal obstruction with the PlastiBell technique have been previously described in the literature (1,2). Necrotizing fasciitis as a complication of circumcision is rare, and all cases reported seem to be associated with the PlastiBell technique (2,3). The finding of cyanosis below the umbilicus after circumcision due to meatal obstruction caused by a misplaced PlastiBell ring resulting in bladder distension and obstruction of venous return has also recently been described (1). A review of circumcision complications suggest that these may occur more frequently than is conventionally believed (2,4).

The members of the Paediatric Death Review Committee of the Office of the Chief Coroner of Ontario were collectively aware of complications from their own institutions, including two children with necrosis of the glans, two infants requiring transfusion, one infant with a buried penis secondary to circumcision, numerous cases of retention of a PlastiBell ring, one infant with a slipped PlastiBell ring causing a penile tourniquet, and one infant with meatal obstruction due to a misplaced PlastiBell ring (Figures 2A and 2B). None of these complications were reported in the medical literature and are therefore not available in a retrospective literature review. It is concerning that none of the initial three physicians who saw this infant, including the physician who performed the procedure, identified this problem as a meatal obstruction, although they were all concerned about a possible link with the recent circumcision.

In this infant, there was no description of the glans by the physician removing the PlastiBell ring. If the foreskin is pulled too tight, then there will be considerable tension pulling the ring against the glans, thus compressing the urethra and making urination difficult or impossible. This is the mechanism described in the case report by Ly and Sankaran (1). We propose the mechanism shown in Figure 2B, given the rapid onset of symptoms, suggesting a complete obstruction. These could be differentiated clinically. In Figure 2A, the meatus would not be visible. The

Coroner's Corner

management of both complications would be the immediate removal of the PlastiBell ring. Perhaps a prospective surveillance study by the Canadian Paediatric Society of the complications of circumcision is warranted. Such a study would provide more accurate information for the ethical requirement of informed consent.

Acknowledgements:

The Paediatric Death Review Committee thanks the parents for their permission to report this case, and the medical graphics department at the Hospital for Sick Children for the illustrations.

References:

1. Ly L, Sankaran K. Acute venous stasis and swelling of the abdomen and extremities in an infant after circumcision. *CMAJ* 2003; 169:216-7.
2. Circumcision Information and Resource Pages. Complications of Circumcision. <www.cirp.org/library/complications> (Version current at March 21, 2007).
3. Bliss DP Jr, Healey PJ, Waldhausen JH. Necrotizing fasciitis after Plastibell circumcision. *J Pediatr* 1997; 131:459-62.
4. Sullivan P. Infant's death another nail in circumcision's coffin, group says. *CMAJ* 2002;167:789.

**This article is reproduced with permission,
Paediatr Child Health 2007;12(4):311-312.**



Figure 1 Correctly positioned PlastiBell ring (Hollister, USA)

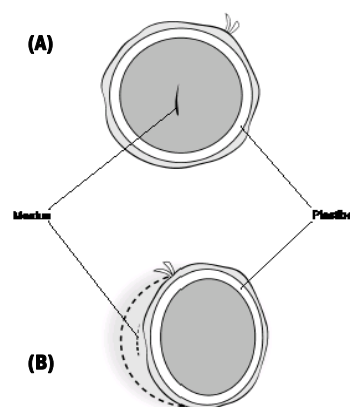

Figure 2 (A) Slipped PlastiBell ring (Hollister, USA) causing tourniquet; B) Slipped PlastiBell ring causing meatal obstruction

Morphine Poisoning in a Breastfed Infant of a Codeine-Prescribed Mother

In 2005, a full-term healthy male infant, demonstrated intermittent periods of difficulty breastfeeding and lethargy beginning on day 7 of life. On day 11, during a routine visit to a paediatrician, it was noted the infant had regained his birthweight. On day 12, his skin appeared 'grey' and milk intake had fallen. He died at home on day 13.

Following post mortem examination, no anatomical cause of death was established. Full toxicological analysis was ordered (as per Deaths Under Two Protocol).

Blood concentration of morphine, which is the active metabolite of codeine, was recorded as 70 ng/mL. Typically breastfed infants, by mothers receiving codeine, have morphine serum levels of 0 to 2.2 ng/mL.

Mother had been prescribed a combination of codeine 30 mg and paracetamol 500 mg following birth for episiotomy pain. The medications were taken according to prescribed doses.

Due to poor feeding, mother stored breastmilk on day 10, which was later analyzed (morphine concentration of 87 ng/mL was found; typical range would be 1.9 to 20.5 ng/mL).

Genotype analysis was done for cytochrome CYP2D6 which catalyzes codeine to morphine; the mother and maternal grandmother were classified as ultra-rapid metabolizers. The father, maternal grandfather and infant were classified as extensive metabolizers. The clinical and laboratory picture is consistent with opioid toxicity leading to neonatal death. Several strategies can be considered to prevent life-threatening neonatal toxicity for codeine-prescribed mothers, these are described in the full case report in *The Lancet*. Whichever clinical approach is taken, codeine cannot be considered as a safe drug for all infants during breastfeeding.

G Koren, J Cairns, D Chitayat, A Gaedigk, S J Leeder. Pharmacogenetics of morphine poisoning in a breastfed neonate of a codeine-prescribed mother. *Lancet* 2006; 368:704

Fluid and Electrolyte Administration in Children

Acute hyponatraemia is defined as a fall in serum sodium to < 130 mmol/L within 48 hours, which can result in acute cerebral oedema and brain stem herniation and has frequently been associated with the administration of intravenous (IV) hypotonic fluids in children, particularly in the peri-operative period.

These patients retain water due to the failure of the normal physiological response, which would be the inhibition of ADH secretion and excretion of a dilute urine. Non-physiological stimuli for ADH secretion include pain, vomiting, anxiety, narcotics, anesthetic agents and positive pressure ventilation. Isotonic fluids, which contain no electrolyte free water, will reduce this risk but not eliminate it. Studies have shown that intraoperative volume expansion with isotonic fluids results in the excretion of a hypertonic urine and hyponatraemia, a process referred to as desalination. The use of hypotonic saline in the post-operative period increases the risk of developing acute hyponatraemia.

The Paediatric Death Review Committee has reviewed 6 acute hyponatraemia related deaths in the last 10 years. The PDRC are of the opinion that inappropriate fluid management in these cases was a contributing factor in these deaths. These children died during the postoperative period, with post mortem findings of cerebral oedema due to acute hyponatraemia. Commonalities have been noted in these cases such as: the amount and type of IV fluid administered peri-operatively not being recorded on the anaesthetic record; use of hypotonic saline in the post-operative period, thereby increasing the risk of developing acute hyponatraemia.

The Committee endorses the following guidelines, developed by Sick Kids Hospital in Toronto to facilitate appropriate screening, prescription and monitoring of IV fluids and electrolyte administration in patients. The PDRC recommend similar guidelines be considered for implementation by any hospital that treats children. The cases reviewed by the Office of the Chief Coroner and the PDRC occurred not only in paediatric centres, but in community hospitals.

Clinical Practice Guidelines - Summary

The purpose of this clinical practice guideline is to facilitate appropriate screening, prescription and monitoring of IV fluids and electrolyte administration in all appropriate patients admitted to hospital. The target users of this guideline are physicians, nurses and paramedics.

This guideline should be followed when prescribing IV maintenance fluids, defined as those required to replace urine output and insensible losses, in children not receiving enteral fluid. IV fluids prescribed to replace losses from the GI tract and other ECF compartments should be of the same electrolyte composition as the fluid that is being lost. This guideline **excludes** patients in neonatal intensive care units.

Indications:

Intravenous fluids are prescribed in paediatric patients for the following indications:

- maintenance fluid therapy** to replace urine output and insensible losses in patients with reduced or no oral intake;
- bolus fluid therapy** to expand the circulating volume in children with hypovolaemia or shock; or
- fluid therapy to replace abnormal losses** from the GI tract and other body cavities.

Prescription of IV Fluid Therapy

0.2 NaCl with 5% Dextrose and 2/3 & 1/3 (0.3 NaCl with 3.3% Dextrose) or 5 or 10% dextrose in water all contain substantial amounts of electrolyte free water and **must not be used as maintenance IV fluids**. Patients with a demonstrable free water deficit may require the administration of these types of hypotonic solutions. The use of these fluids is **restricted to the CCU, NICU, Endocrinology and Nephrology services**. Consultation should be obtained from the appropriate one of these services if these solutions are being considered.

References:

- Choong K, Kho M, Menon K, Bohn D. Hypotonic versus isotonic saline in hospitalised children: A systematic review. Arch Dis Child 2006.
- Duke T and Molyneux EM. Intravenous fluids for seriously ill children: time to reconsider. The Lancet. 2003; 362:1320-1323.
- Taylor D, Durward A. Pouring salt on troubled waters. Archives of Disease in Childhood 2004;89(5):411-4.
- Neville KA, Verge CF, Rosenberg AR, O'Meara MW, Walker JL. Isotonic is better than hypotonic saline for intravenous rehydration of children with gastroenteritis: a prospective randomised study. Arch Dis Child 2006;91(3):226-32.
- Hoorn EJ, Geary D, Robb M, Halperin ML, Bohn D. Acute hyponatremia related to intravenous fluid administration in hospitalized children: an observational study. Pediatrics 2004;113(5):1279-84.
- Burrows FA, Shutack JG, Crone RK. Inappropriate secretion of antidiuretic hormone in a postsurgical pediatric population. Crit Care Med 1983;11(7):527-31.
- Wilkinson E, Rieff J, ReKate HL, Beals S. Fluid, blood, and blood product management in the craniofacial patient. Pediatric Neurosurgery 1992;18(1):48-52.
- Sarnaik AP, Meert K, Hackbarth R, Fleischmann L. Management of hyponatremic seizures in children with hypertonic saline: a safe and effective strategy. Crit Care Med 1991;19:758-762.
- National Patient Safety Agency, United Kingdom. Patient Safety Alert 22: Reducing the risk of hyponatraemia when administering intravenous infusions to children. March 2007. www.npsa.nhs.uk/health/alerts

Clinical Practice Guideline developed at Sick Kids Hospital and approved by their Medical Advisory Committee.

Fluid and Electrolyte Administration in Children: Guideline

Assessment: Lab Tests		
Condition	Lab Tests to be ordered	
Prior to IV fluid administration	<ul style="list-style-type: none"> • Serum electrolytes (Na, K, glucose, urea, creatinine) • Timing: At the time of the decision to administer 	
<u>ALL</u> patients receiving maintenance IV fluids at >50% calculated maintenance levels or replacement IV fluids for ongoing losses	<ul style="list-style-type: none"> • Daily serum electrolytes (Na, K) • Daily intake and output • Daily weight measurement 	
Prescription of IV Fluids		
Condition	Recommendations for IV Fluids prescription	Na concentration in solution (mmol/L)
IV Bolus (use for severe ECF Contraction /impending Shock)	• 0.9% NaCl with or without dextrose*	154
	• Ringers Lactate with or without dextrose*	130
Perioperative	• 0.9 NaCl with or without dextrose*	154
	• Ringers Lactate with or without dextrose*	130
Unknown	• 0.9 NaCl with or without dextrose* <u>or</u>	154
	• Ringers Lactate with or without dextrose* (contains 4 mmol/l potassium)	130
Serum [Na+] < 138 mmol/L	• 0.9% NaCl with or without dextrose* <u>or</u>	154
	• Ringers Lactate with or without dextrose*	130
Serum [Na+] = 138 – 144 mmol/L	IV fluids should contain a sodium concentration of 77-154 mmol/L such as:	
	• 0.45 NaCl with or without dextrose* <u>or</u>	77
	• 0.9 NaCl with or without dextrose* <u>or</u>	154
	• Ringers Lactate with or without dextrose*	130
Serum [Na+] = 145 – 154 mmol/L	• IV fluid sodium concentration should approximate one half normal saline, such as:	
	• 0.45 NaCl with or without dextrose <u>or</u>	77
Serum [Na+] >155 mmol/L	• 0.2 NaCl with or without dextrose <u>or</u>	34
	• D5W	0
<p><i>*Solutions with added dextrose may be required based on patient age and the blood glucose level. KCl to be added to IV solutions depending on plasma level.</i></p>		

PDRC Reviews of Cases with Children's Aid Involvement

While the PDRC does not assign blame in the death of a child, it does review cases with a viewpoint of prevention. One of the roles of the PDRC is to make recommendations to prevent deaths in similar circumstances. For example, these questions are considered: Could this child's death have been prevented? Could similar child deaths in the future be prevented? If so, how?

All child deaths are tragic and are usually the result of various factors; occasionally the actions or inactions by those in a care-giving role (parents and or/systems) play a part in the circumstances leading up to a fatality. The PDRC reviews these circumstances and makes recommendations for consideration by the Child Welfare system and others in hopes of preventing further child fatalities.

Recognizing the committee has the benefit of hindsight in conducting its assessment of agency practices, it is helpful to bear in mind the following questions posed by Dr. Peter Markesteyn (from the Turner Review and Investigation September 2006):

- What did they know at the time of the events?
- What could they have known, but didn't when those events occurred?
- Based on what they then knew or could have known, were their decisions appropriate?

Generally the Committee acknowledges the difficult work of the Children's Aid Societies in protecting children from harm. There are occasions however, in some cases, where concerns are identified with the decision-making, management of cases or the provision of services to families and children.

Many children's deaths are preventable; it is particularly concerning when a child dies needlessly and contributing factors include the services that they have or have not received by a child protection agency. Two specific cases are highlighted here where the committee believed that different decisions, based on the information known or that could have been known at the time, might have resulted in different outcomes for a child.

Case Summary #1:

A young boy was sexually assaulted and a victim of homicide by a family member, a convicted sexual offender. The family was known to the local CAS for most of fourteen years with a history characterized by violence between the parents, poor supervision practices, a pattern of neglect and minimal involvement and follow-up with support services.

All of the family members were aware that the children should never be alone with this man. Repeatedly, the CAS warned the man's partner and the parents; however, the workers did not appear to have any involvement with him directly. The CAS had information that the parents were inconsistent and unreliable regarding the access restriction and the offender's partner did not actively comply with the expectation that the children never be alone with him. A court order was never sought to protect the children and they were never removed from the care of the parents. Agency monitoring and decision making practices were questioned by the PDRC and recommendations were made to the agency and its Board of Directors to help prevent a similar outcome in the future.

Case Summary #2:

An infant girl died of a non-accidental head injury in the care of her father. The CAS file revealed that there was a long history with the mother's family of origin concerning issues of neglect, physical abuse, domestic violence, and drug and alcohol abuse. The mother was referred to CAS regarding concerns about leaving her older child unsupervised, drug and alcohol abuse, non-compliance with agency interventions and suicide threats. The involvement of the CAS was deemed by the PDRC to be below standard in terms of the frequency of visits and ability to actually connect with the mother in person. It was just before the birth of this child that the mother told the CAS that she was pregnant again, demonstrating the limited involvement of the agency over the previous nine months. The case was closed without Society workers ever seeing the baby or meeting the father. Six months later a doctor contacted the CAS with information about the baby's head size and tests that were being done. He stated that he would contact the agency if there was evidence of abuse. He did not call again and no further investigative action was taken by the agency. The PDRC questioned and made recommendations about the actions/inactions of the agency and the medical practitioners.

Summary:

Both cases, albeit from different agencies, were highly concerning to the PDRC. Common themes appear although the circumstances differ. Both cases involve parents who had a history of neglect and non-compliance with agency intervention, services and supports. In neither case was there consideration of using the patterns of non-involvement to go before the court to protect the children. Both cases had features that related to lack of a consistent oversight of the family for appropriate decision making. Themes repeatedly seen by the PDRC over the years include lack of understanding and action by agencies on patterns of child neglect. These cases raise the question of whether these children should have remained in the care of their respective caregivers without more intrusive intervention, given the information that was or could have been available at the time prior to their unfortunate deaths.

PDRC Reviews of Cases with Children's Aid Involvement

DEATHS OCCURRING in 2006:

- 83 children died with an open file or having had an open file to a CAS within the previous 12 months
- 64 had open files at the time of death and 19 had files that closed within the previous 12 months
- 31 of these children were female, 52 were male
- 43/83 were <5 years old; 30/43 (70%) were < 1 year of age
- Of the 30 infants <1 year who died, 15 (50%) were found in an unsafe sleeping environment and/or co-sleeping with an adult
- 19/83 children were in the care of CAS (10 were Crown Wards; 2 were on an Extended Care and Maintenance program)
- 41 (45.5%) of the cases resulted in a request for a Society Internal Review

Manner of Death:

- Of the 83 children who died in 2006, the manner of death has been classified in 60 of them (the other 23 remain under investigation): 16 natural; 8 suicide; 11 homicide; 14 accident; 11 undetermined
- 5/8 youths who committed suicide were from First Nations Communities
- Cause of death for the 30 infants under 1 year of age (4 are still under investigation): 16 SUD; 7 various natural diseases; 1 SIDS; 1 drowning; 1 compressional asphyxia

Due to the volume of cases and the length of time required for a complete coroner's investigation including various test results, all fatalities cannot be reviewed in the same year of death (see fig 1 below). Additionally, cases before the criminal courts are generally not reviewed until the charges are resolved.

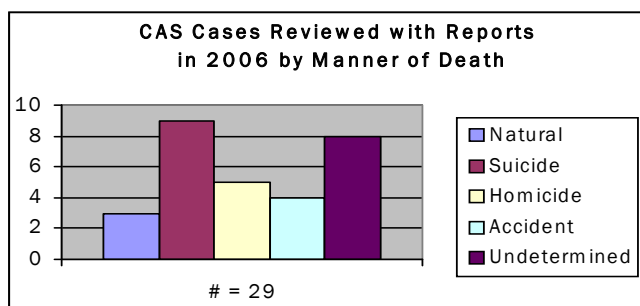
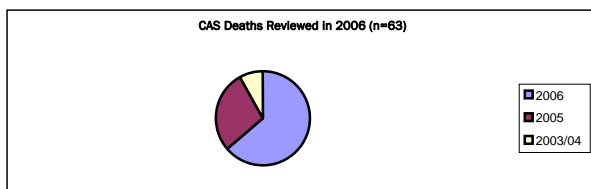

DEATHS REVIEWED in 2006:

While 83 children died in 2006 while having an open file or having been open in the preceding 12 months to a Children's Aid Society, all of these deaths were not reviewed in the same year. The following analysis is based on the 29 CAS cases in which the Paediatric Death Review Committee issued a report with recommendations in 2006. The remaining child fatalities will be reported on in more detail in the year of their review.

- A total of 63 child deaths were reviewed by the Paediatric Death Review Committee in 2006
- 34 reviews of deaths from 2006 occurred without a full report being necessary; 13 (38%) of these deaths were of "medically fragile" children; the remaining 21 were natural, clearly accidental or, in the case of 2 homicides, the CAS file was opened as a result of the death (no previous involvement)
- 29 full reports with recommendations were completed and issued by the Committee (see figure 2); the following data is based on these cases
- Of these 29 reviews, 6 were of 2006 deaths; 18 were of 2005 deaths; 5 were of deaths from 2003/04
- Of the 29 PDRC reviewed deaths in 2006, 12 children were female and 17 were male
- 11 of the children were under 5 years of age, 18 were over 5 years of age; 14 of those being over 12
- 8/11 children under 5 were less than 1 year of age
- 26/29 of the children reviewed had open files at a Children's Aid Society (CAS); 3/29 had closed files but had received service within the past 12 months. 4 of the children were in the care of a CAS

Manner of Death:

- Of the 29 child deaths reviewed in 2006, the Manner of Death was classified as: 3 Natural; 9 Suicide; 5 Homicide; 4 Accident; 8 Undetermined
- 6/9 youths who committed suicide were from First Nations Communities; the youngest being 13 years old
- 4/5 homicides were committed by a caregiver; 1 by an unrelated individual, likely known to the caregiver
- The 4 accidental deaths were the result of drowning (2), solvent abuse (1) and carbon monoxide poisoning (1)
- The cause of death of the 8 infants under one year of age was Sudden Unexpected Death (SUD); 6/8 died in an unsafe sleeping environment and/or co-sleeping or bed-sharing with an adult

Case Reviews Involving Children's Aid Societies: THEMES

It is hoped that by identifying thematic weaknesses in the management of cases or in the provision of services, changes to best practices can be made that would prevent future similar fatal results for children receiving services from a Children's Aid Society.

The following are repeated themes noted by members of the PDRC in their analysis of the Child Welfare cases reviewed in 2005-2006, followed by recommendations made, grouped into three categories:

(1) Direct Service and Case Management; (2) Assessment and Decision-making; and, (3) Child Death Investigations and Review.

1. **Direct Service and Case Management**

- CAS worker's were over reliant on self-reporting by parents, and frequently did not verify information provided by caregivers.
- Little attention was paid to safe sleeping practices when assessing home environments.
- There was a lack of case conferences involving relevant collaterals (such as doctors, teachers, probation officers, other therapists, nurses)
- There were inconsistencies across the province in the provision of service to high risk infants.
- There was exclusion of input from the non-custodial/non-offending parent
- There was incomplete and out of compliance paperwork making file reviews difficult.

2. **Assessment and Decision-making**

- Inconsistent recording of supervisory oversight and consultation.
- Premature closing of cases due to parents' uncooperativeness or refusal to sign consent for collateral contacts.
- Failure to thoroughly complete record checks on new adults in the home/family.
- Insufficient attention paid to themes, patterns and multiple openings, particularly when neglect is an issue.
- Focus on one protection concern at the expense of other reasons a file is open.

3. **Child Death Investigations**

- There were inconsistencies in the completion of child death investigations by CAS
- Inconsistencies in following and using a standard joint investigative protocol between police and CAS
- The role of parental negligence in accidental or undetermined deaths was seldom considered.
- There was poor communication and poor sharing of information with professional collaterals involved with the families and co-investigators.

Case Reviews Involving Children's Aid Societies: RECOMMENDATIONS

It is acknowledged that some of the recommendations from recent reports of the PDRC have already been implemented and have resulted in changes to agency practices and policies and are evident in the current Child Welfare Transformation including revised provincial child protection standards and legislation. From cases reviewed in 2005-2006, the following recommendations were made. Suggestions for further training were also identified.

Direct Service and Case Management

- Weekly home visits for infants < 6 months
- Public Health Nurse or Child Health Specialist to see all children under 2 on a regular basis
- Drug testing vs. relying on parents' self-reporting of substance abuse
- Enhanced awareness and education for workers and parents regarding the risks of co-sleeping and unsafe sleeping environments
- Regular case conferences with internal and external service providers (including group home providers and medical practitioners)
- Contacting and including access parents in investigation and assessments
- Following up and utilizing mandated authority when clients refuse to sign consents for contacting child's medical/psychological service providers
- Checking records on all new adults in the home or family
- Compliance with, and standardization of, paperwork requirements
- Enhanced sharing of information with collaterals and new workers

Assessment and Decision-making

- Pay attention to chronic themes/patterns; multiple openings
- Regular review of the approach to servicing families that are demonstrating little progress over time (i.e. the use of more intrusive measures such as court and parenting capacity assessments to protect children from chronic neglect and low parenting capacity)
- Following up with collaterals and verifying information provided by parents regarding services and medical attention
- Not focusing on one protection issue at the expense of others
- Mandatory review of all cases where closing is being contemplated solely due to non-compliant clients

- Obtaining and using client histories and past openings in assessment of risk
- Considering the possibility of parental negligence when the manner of death is accidental or undetermined

Child Death Investigation and Review

- Mandatory Police and CAS protocols for joint investigations and reporting of all child deaths
- Investigations to consider verification decisions and/or placement on Child Abuse Register as appropriate

Identified Areas for Further Training

- SIDS
- Co-sleeping/unsafe sleeping environments
- Mental health/adolescent depression and suicide
- Substance abuse/solvent abuse in adolescents
- Case note writing and file organization
- Use of cultural interpreters as needed
- Understanding issues of medically fragile children
- Child Death Investigations, Reporting, Review and Prevention
- Forensic Investigations
- Developing internal capacity for conducting internal reviews on child deaths

Accolades

Despite the number of recommendations made for improvements to best practice, the PDRC regularly provides positive feedback to Children's Aid Societies for their ongoing work with children and families. Examples of accolades offered in 2005-2006 include:

- Internal reviews – good critical analysis by reviewers/agencies
- Comprehensive work plans to address recommendations from internal reviews and the PDRC
- Multiple services provided and offered by agencies to children and families
- Commitment and support provided by agencies and staff to clients and foster parents after the death of a child
- Agency support to workers after the death of a child on their caseloads
- Good use of community and internal resources to assist families

Internal Child Death Reviews: Best Practice Guidelines for Children's Aid Societies

It has been a year since the implementation of the revised Joint Directive on Child Death Reporting and Review (March 31, 2006). The Paediatric Death Review Committee has received approximately 30 society internal death reviews thus far and, with the Ontario Association of Children's Aid Societies (OACAS), have been asked clarifying questions on how best to conduct and write these reviews. Based on our experiences to date, we offer these guidelines to assist Children's Aid Societies in conducting internal child death reviews that are clear, comprehensive, meaningful and somewhat consistent.

Child death reviews are intended to explore the circumstances relating to the child's death, in order to ascertain what might be changed systemically or in professional practice to reduce the risk of another similar child death in the future and to strengthen practice in general. Reviews are undertaken by agencies for purposes of learning. The following are suggested Best Practice Guidelines for Children's Aid Societies when conducting internal reviews of child deaths:

- Follow the OACAS Internal Child Death Review Guidelines and Template (January, 2006)
- Include external reviewer expertise on a review team including internal child welfare experts with a goal of developing and maintaining internal expertise in conducting death reviews
- External Reviewers – should have extensive experience in the child welfare field and have no conflict of interest or direct involvement in the case
- The members of the review team (external and internal) should be identified by name, position, experience, and relationship to the agency
- The reviews should be completed within the time frame specified in the Joint Directive. If necessary, an extension may be requested from the Coroner's Office.
- Include in the review updates and follow-up with the family after the death of a child
- Include the agency's plan and time lines for addressing its recommendations arising from the review
- Identify the child by its name (first name plus initial of last)
- Reference any agency policies and/or protocols reviewed while conducting internal reviews
- Do not assume that the cause of death has been established prior to completion of the Coroner's investigation including full autopsy, toxicology and other tests. Cases may need to be reviewed by PDRC and/or Deaths Under Five Committee before the cause and manner of death are finalized (this may take up to 6 months). While information from the investigation may be shared with the Society, copies of the documents may not be. Consultation with the Coroner's office is available as necessary.

Future Directions

Since the last report of the PDRC in 2004, the following initiatives which were identified for consideration, have taken place:

- **The production of an annual report on the activities of the Paediatric Death Review Committee** (*The current report issued as a direct result of additional resources made available to the PDRC through the Ministry of Children and Youth Services/Child Welfare Secretariat*)
- **A review of the Death Review Protocol for Child Welfare Cases by the Ministry of Children and Youth Services (MCYS), OACAS, and the Office of the Chief Coroner** (*Revised Joint Directive issued in March 2006*)
- **The development of an Internal Death Review Protocol for Children's Aid Societies in Ontario** (Task Force launched by OACAS) (*Guidelines issued through the OACAS in January 2006*)

The following points highlight areas for consideration to improve the child death review process in the Province of Ontario:

- The continued work with the Ministry of Children and Youth Services and the Child Welfare Secretariat to ensure ongoing support and resourcing of the Child Death Review Process and continued sharing of information on child deaths and PDRC recommendations
- The analysis of "Lessons Learned" from individual society internal child death reviews and sharing these lessons with the broader child welfare field
- The development, revision, and delivery of training on Child Death Investigations, Reporting and Reviewing for CAS workers
- The enhancement of public and professional awareness of the risks to infants of bed-sharing and unsafe sleeping environments
- Liaising with other provincial and international Child Death Review Committees to sharing resources and ideas
- The continued provision of an expert, objective, and transparent process to review deaths of children in Ontario which has a goal to enhance learning, recommend systemic changes as needed, and to reduce and prevent future child fatalities.
- The creation and propagation of a "blame free" culture to encourage an environment which seeks to openly identify and reduce errors and omission
- An increase in the number of child welfare experts on the Paediatric Death Review Committee to assist in review of CAS cases

Committee Membership

Paediatric Death Review Committee (PDRC)

Dr. James Cairns—CHAIR

Deputy Chief Coroner for Ontario
Office of the Chief Coroner

Ms. Karen Bridgman-Acker—Coordinator (CAS)

Child Welfare Specialist
Office of the Chief Coroner

Ms. Dorothy Zwolakowski—Coordinator (MEDICAL)

Executive Officer, Investigations
Office of the Chief Coroner

Ms. Susan Abell

Child Welfare Consultant

Dr. Desmond Bohn

Chief, Department of Critical Care Medicine
Hospital for Sick Children, Toronto

Det. Sgt. Chris Buck

Homicide Squad, Toronto Police Service

Dr. Ted Cormode

Paediatrician, Orillia

Ms. Zel Fellegi

Director, Aisling Discoveries Child & Family Centre
Scarborough

Det. Sgt. Gary Giroux

Homicide Squad, Toronto Police Service

Ms. Jeanette Lewis

Executive Director
Ontario Association of Children's Aid Societies

Ms. Sandy Moshenko

Child Welfare Consultant

Dr. Ram Singh

Director, Paediatric Critical Care Unit
London Health Sciences Centre

Ms. Lorna Spencer

Coroners Counsel
Office of the Chief Coroner

Det. Sgt. James Stewart-Haass

Homicide Unit, Durham Regional Police

Dr. Glenn Taylor

Head, Division of Pathology
Hospital for Sick Children, Toronto

Det. Sgt. Kevin Torrie

Homicide Squad, York Regional Police

Dr. John Watts

Associate Chair, Department of Paediatrics
McMaster University Medical Centre, Hamilton

Dr. Robin Williams

Medical Officer of Health
Niagara Region Public Health

Dr. Ian Wilson

Paediatrician, Kitchener

Det. James Wingate

Coroners Investigator

Membership also includes: Coroners Investigators (OPP and Peel Regional Police) from the Office of the Chief Coroner

Deaths Under Five Review Committee (DU5C)

Dr. James Cairns—CHAIR

Deputy Chief Coroner for Ontario
Office of the Chief Coroner

Ms. Dorothy Zwolakowski—Coordinator

Executive Officer, Investigations
Office of the Chief Coroner

Det. Sgt. JJ Allan

Homicide Unit, Durham Regional Police

Det. Staff Sgt. Dominic Beckett

Coroners Investigator

Ms. Karen Bridgman-Acker

Child Welfare Specialist
Office of the Chief Coroner

Det. Sgt. Chris Buck

Homicide Squad, Toronto Police Service

Dr. David Chiasson

Director, Paediatric Forensic Pathology Unit
Hospital for Sick Children, Toronto

Det. Sgt. Gary Giroux

Homicide Squad, Toronto Police Service

D/C Lisa McIntyre

Coroners Investigator

Dr. Barry McLellan

Chief Coroner
Province of Ontario

Dr. Michael Pollanen

Chief Forensic Pathologist
Province of Ontario

Det. Sgt. Cheryl Schatz

Coroners Investigator

Dr. Gino Somers

Paediatric Forensic Pathologist
Hospital for Sick Children, Toronto

D/C Barb Spoelstra

Coroners Investigator

Dr. Glenn Taylor

Head, Division of Pathology
Hospital for Sick Children, Toronto

Det. Sgt. Kevin Torrie

Homicide Squad, York Regional Police

Det. James Wingate

Coroners Investigator

D/C Cathy Zimmer

Coroners Investigator

Acknowledgements

Thank you to the following individuals who assisted in the production of this report:

Paediatric Death Review Committee & Deaths Under Five Committee

To past and current members for their ongoing commitment and support in child death reviews

Cheryl Simpson and Neda Vujicic

2nd Year Medical Students, University of Toronto
SUD Review: Co-sleeping and other risk factors
SIDS Review: Risk Factors/Prevention

Reference Materials

Office of the Chief Coroner

www.mpss.jus.gov.on.ca/english/pub_safety/office_coroner/about_coroner.html

AAP (American Academy of Pediatrics)

www.aap.org

OACAS (Ontario Association of Children's Aid Societies)

www.oacas.org

SIDS Foundation of Canada

www.sidscanada.org

Canadian Pediatric Society

www.cps.ca

National Association of Medical Examiners

www.thename.org

Health Canada: Consumer Product Safety

www.hc-sc.gc.ca/cps-spc/pubs/cons/bath_seat-sieges_e_bain_e.html

National Patient Safety Agency

Patient Safety Alert 22: Reducing the risk of hyponatraemia when administering intravenous infusions to children. March 2007

www.npsa.nhs.uk/health/alerts

U.S. Consumer Product Safety Commission

www.cpsc.gov

Consumer Reports

www.Consumerreports.org

United Kingdom Department of Health

www.dh.gov.uk/cotdeath/

Statistics Canada

www.statscan.ca

Journal Articles:

Coroners Corner Articles written by the Paediatric Death Review Committee are published periodically in the *Journal of Pediatrics and Child Health* (www.cps.ca) - Most recent publications appear in the 2007 issues on ***Circumcision: A minor procedure?*** (*Paediatr Child Health* 2007; 12(4):311-312) and ***Rapid onset of coma and death in the initial presentation of type 2 diabetes in an 11-year-old child*** (*Paediatr Child Health* 2007;12(1):41-42)



Office of the Chief Coroner Province of Ontario

26 Grenville Street
Toronto, Ontario
M7A 2G9

Contacts:

Dr. Jim Cairns

Deputy Chief Coroner for Ontario
Phone: 416-314-4014

Ms. Karen Bridgman-Acker

Child Welfare Specialist
Paediatric Death Review Coordinator—CAS
Phone: 416-314-4011

Ms. Dorothy Zwolakowski

Executive Officer, Investigations
Paediatric Death Review Coordinator—Medical
Phone: 416-314-4017